

d(mm)	Part No.	L(mm)	Grip Range(mm)		Drill Size (mm)	D(mm)	S(mm)	dm(mm)	P(mm)	Tracción Tensile (N)	Cizalla Shear (N)
			Min	Max		Max	Max	Max	Min		
d=6,4	R03064125	12,5	1,5	6,5	6,5	12,7	2,5	3,65	30	4900	3600
	R0306414	14	3,0	8,0							
	R03064155	15,5	4,5	9,5							
	R0306416	16	5,0	10,0							
	R03064195	19,5	8,5	13,5							
	R0306422	22	11,0	15,5							
	R0306424	24	13,0	17,5							

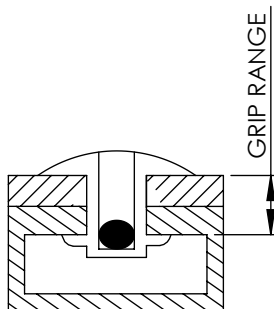
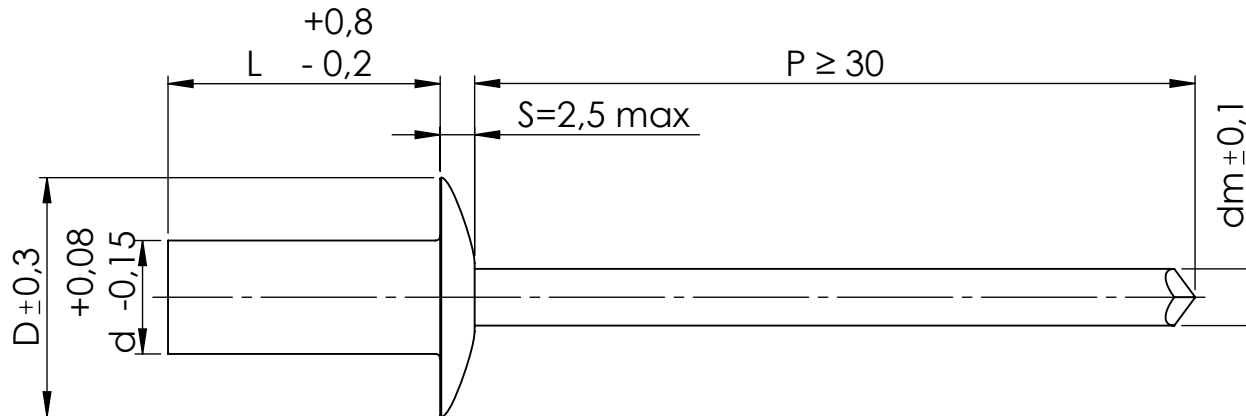

Este plano es propiedad de Remaches Tudela S.L. todos los derechos reservados/ This drawing is the property of Remaches Tudela S.L. all rights reserved											
DIBUJADO / DRAWN BY FECHA / DATE		J.SANZ 15/11/2021		DENOMINACIÓN DESCRIPTION		REMACHE CABEZA ALOMADA ESTANCO/ DOME HEAD SEALED RIVET		ESPECIFICACIONES GENERALES GENERAL SPECIFICATIONS			
REVISIÓN / REVISION FECHA / DATE		Rev. 0 15/11/2021		CUERPO / BODY		CLAVO / MANDREL		TOLERANCIAS Según plano/ TOLERANCES According drawing			
REMACHES TUDELA		MATERIAL		ALUMINIO 5% MG ALUMINUM 5% MG		ACERO STEEL		UNIDADES mm			
		ACABADO FINISHED		ABRILLANTADO BRIGHTNESS		FOSFATADO PHOSPHATED		REFERENCIA REFERENCE			
						R03064		⊕		A4	